

MP3 Design Project

Using Pro/ENGINEER and RapMan

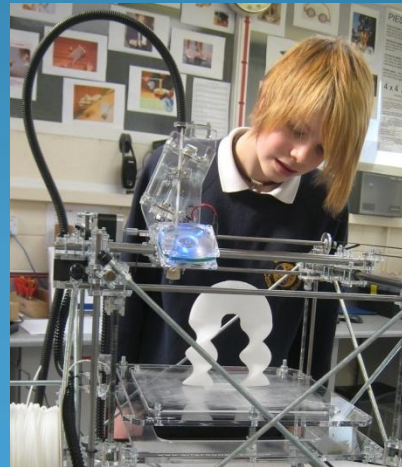

Brief

Context: MP3 players are very popular for storing music (and video) in a compact and portable format. One of the major manufacturers has decided that their current range of players needs to be updated.

Brief: Design a new portable music/video player to update the players produced by one of the major manufacturers.

Research

- Produce a “Moodboard” with examples of existing MP3 players.
- Analyse these players to find out what features are common to the different designs or manufacturers.
- Carry out some consumer research to find out what different target users would like MP3 players to do.
- Find some anthropometric data that is relevant to the design of the MP3 player and maybe do some simple modelling (styrofoam or card nets) to test the ergonomics of MP3 players.

Specification

- Write a specification for your new design of MP3 player.
- Don't forget to specify who will be your target user group.
- Specify the main features that your MP3 Player should include.

Modelling ideas

- Sketch some initial design ideas. Think about shape, size and function of your design.
- Does it need a screen (touchscreen?)
- What controls are needed?
- How/where do the headphones connect?
- How is music or video transferred to the MP3 Player (socket, Bluetooth, WiFi ?)
- Produce a 3D model of your best design (use quick modelling materials such as styrofoam, card, modelling clay, etc.)

Design with Pro/ENGINEER

- Now that you have a good idea of what your design would look like you need to create your design in Pro/ENGINEER.
- Set up a new folder to save your work in.
- Start Pro/ENGINEER
- Set the folder you created as your “working directory”
- Click on the “New” button. 
- Select “Part” and also type a name

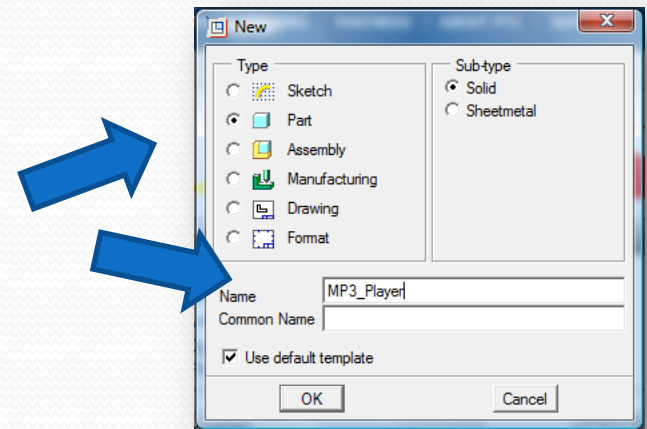

Design hints

- To make manufacturing easier on the RapMan it is best to construct your design on the “Front” workplane.
- Use the “Extrude” tool to create the basic shape of the body part of the MP3 Player.
- Right click on screen and select “Define Internal Sketch” from the menu.
- Pre-highlight (light blue) the front workplane and then click on it.
- Click “sketch” in the popup window accepting the default settings

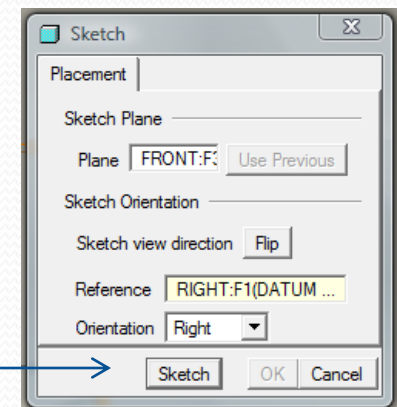
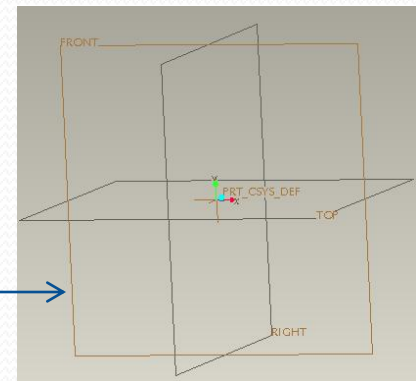

Sketching the body shape

- Inside the sketcher draw the front view of your MP3 Player.
- Don't forget to use the dimensions to “control” the shape and size of your design.
- Do NOT add any details to the design at this stage.
- When you have completed the shape click the blue tick to finish sketching.
- Set the height of the extrusion in the settings dialogue and then click the green tick to finish the extrusion.

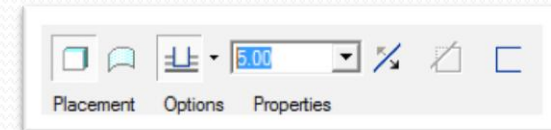
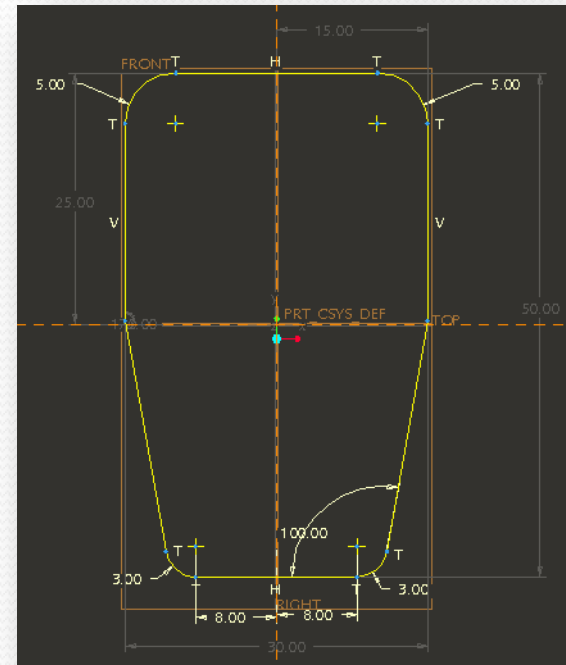

Modifying the design

- Use the “Round” or “Chamfer” features to modify the design.
- Do NOT at this stage do any rounding on the bottom edges (underside) of the design as this will cause difficulties later when making the design on the RapMan.

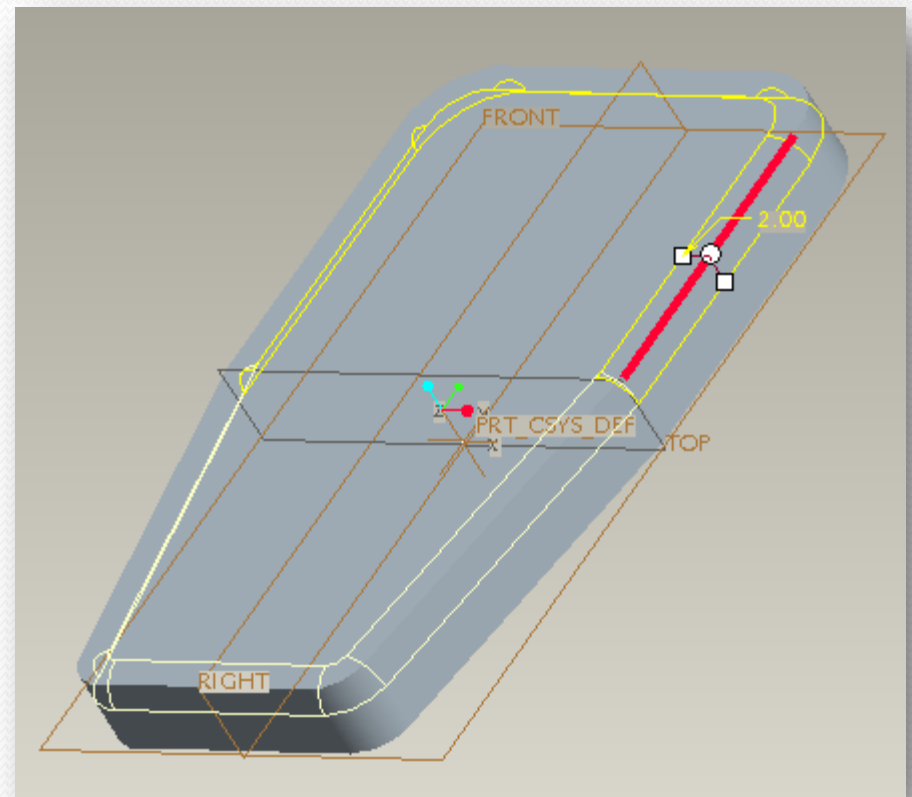

Adding the screen

- Use the Extrude feature to remove material from the body to create an indentation that represents the screen.
- Don't forget to set the depth (A)
- Change the direction of the extrude to downwards (B)
- Set the extrude to remove materials (C)

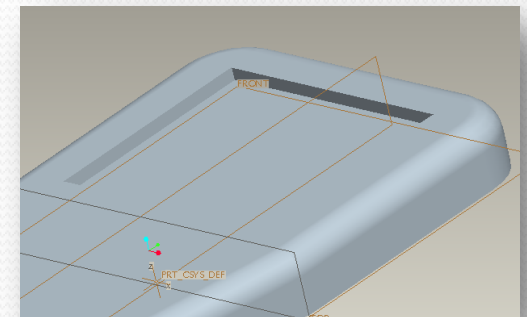
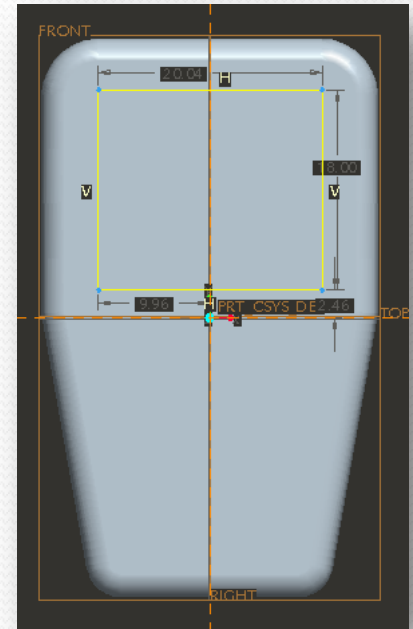
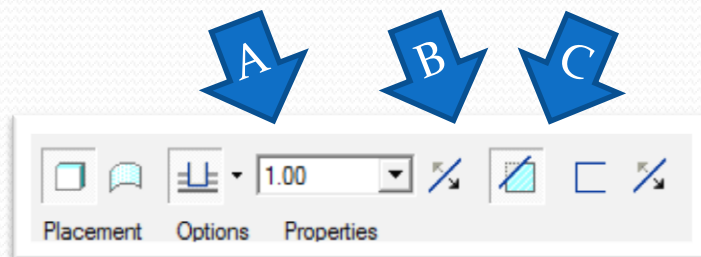

Controls (and other details)

- Use Extrude to add or remove material to the body shape to add features to your design such as a click-wheel, buttons or sockets.
- These can also be modified with rounding or chamfers.
- And maybe add a logo.

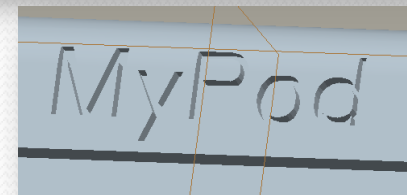
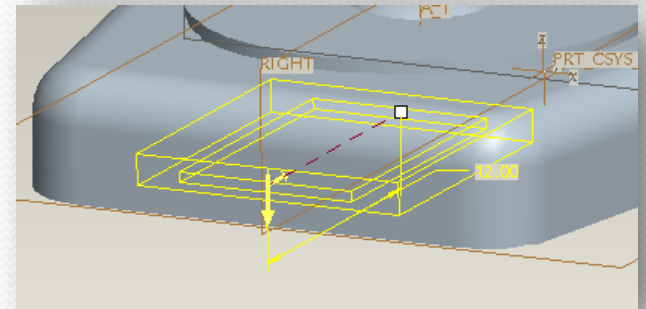
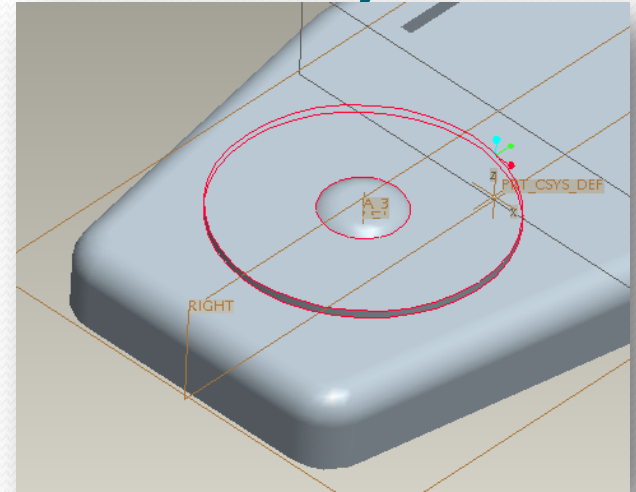

Colour and appearance

- It's really beyond what is required for this project but if you are able to use the “Colour and appearance” feature of Pro/ENGINEER you can render your design to make it very realistic.
- Don't forget to **SAVE** your design!!!



Preparing for manufacture

- The programme that is used to convert your Pro/ENGINEER design into a set of instructions (called G-Code) is called Skeinforge.
- Skeinforge does not understand Pro/Engineer files so you will need to convert it into a Stereo Lithography file (usually known as .stl).
- In Pro/ENGINEER make sure that your design is open then click on “File” and select
- “Save a copy”. When the popup
- window opens select STL and
- click OK.

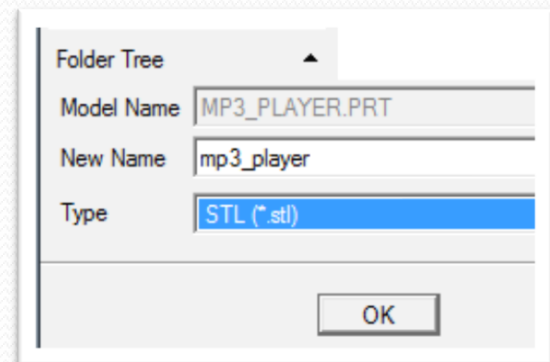

Continued.....

Preparing for manufacture 2

- To export the .stl file you then need to edit a few options.
- Change the format to ASCII
- Type “o” (zero) into the “Chord Height” box and press enter (Pro/ENGINEER will automatically select the smallest value that is possible. This makes the shape as smooth as possible.)
- Click “OK” and the STL file will be automatically saved to your working directory.

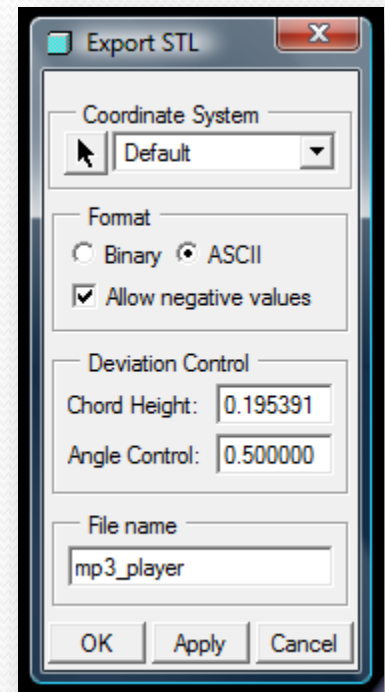

Continued.....

Preparing for manufacture 3

- Pro/ENGINEER will have now converted your design into an STL file. The shape is now just a surface made up of loads of triangles.
- STL files are the standard files used by most Rapid Prototyping machines... Including RapMan.

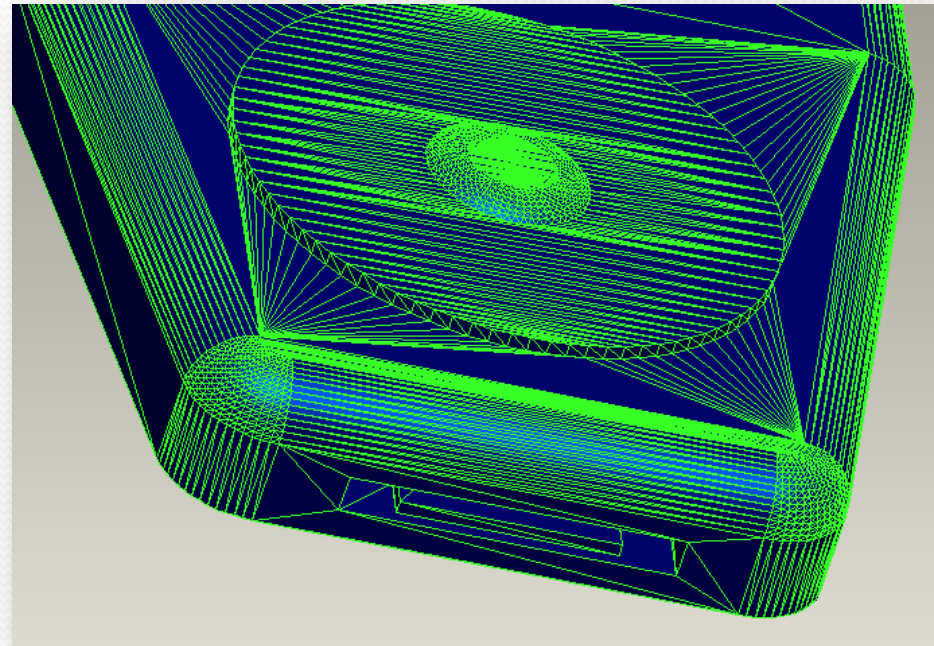

Converting to G-Code

- The STL file now needs to be converted to G-Code (the instructions that control the RapMan. This is covered in a separate PowerPoint- “Skeinforge and Printing”. Or alternatively you can use BfB Axon which is simpler to use.



RapMan

- RapMan is a low cost 3D printer available from Bits from Bytes www.bitsfrombytes.com
- Further assistance can be found on the BfB forum and wiki.

Forum

<http://www.bitsfrombytes.com/fora/user/index.php>

Wiki <http://www.bitsfrombytes.com/wiki>